

Variation of rotation moment arms with hip flexion

Scott L. Delp^{a,*}, William E. Hess^b, David S. Hungerford^c, Lynne C. Jones^c

^a*Biomechanical Engineering Division, Mechanical Engineering Department, Stanford University, Stanford, CA 94305-3030, USA*

^b*Department of Biomedical Engineering, Northwestern University, Evanston, IL 60208, USA*

^c*Department of Orthopaedic Surgery, Johns Hopkins University, Baltimore, MD, USA*

Received in final form 15 December 1998

Abstract

Excessive flexion and internal rotation of the hip is a common gait abnormality among individuals with cerebral palsy. The purpose of this study was to examine the influence of hip flexion on the rotational moment arms of the hip muscles. We hypothesized that flexion of the hip would increase internal rotation moment arms and decrease external rotation moment arms of the primary hip rotators. To test this hypothesis we measured rotational moment arms of the gluteus maximus (six compartments), gluteus medius (four compartments), gluteus minimus (three compartments) iliopsoas, piriformis, quadratus femoris, obturator internus, and obturator externus. Moment arms were measured at hip flexion angles of 0, 20, 45, 60, and 90° in four cadavers. A three-dimensional computer model of the hip muscles was developed and compared to the experimental measurements. The experimental results and the computer model showed that the internal rotation moment arms of some muscles increase with flexion; the external rotation moment arms of other muscles decrease, and some muscles switch from external rotation to internal rotation as the hip is flexed. This trend toward internal rotation with hip flexion was apparent in 15 of the 18 muscle compartments we examined, suggesting that excessive hip flexion may exacerbate internal rotation of the hip. The gluteus maximus was found to have a large capacity for external rotation. Enhancing the activation of the gluteus maximus, a muscle that is frequently underactive in persons with cerebral palsy, may help correct excessive flexion and internal rotation of the hip. © 1999 Elsevier Science Ltd. All rights reserved.

Keywords: Hip; Muscle; Moment arm; Cerebral palsy; Gait

1. Introduction

Persons with cerebral palsy frequently walk with excessive flexion and internal rotation of the hip. The muscles that have the potential to generate hip flexion moments are relatively well defined; thus, stretching exercises and surgical lengthenings that aim to reduce hip flexion can be directed toward specific muscles. For example, it is well known that the psoas has a large hip flexion moment arm. As a result, excessive flexion of the hip is treated by stretching this muscle or by surgical lengthening of its tendon (Skaggs et al., 1997, Sutherland et al., 1997).

The rotational function of muscles about the hip is less well defined. Although anatomical texts provide qualitative descriptions of muscle function in the upright standing position, these texts do not characterize the rotational function of the hip muscles in other body

positions. Moment arms of muscles frequently vary with body position (Hoy et al., 1990; Murray et al., 1995). Thus, rotational moment arms must be evaluated over the range of body positions assumed by persons who walk with exaggerated flexion and internal rotation of the hip to determine which muscles have the potential to generate internal rotation moments in these subjects. Several investigators have quantified the rotational moment arms of muscles about the hip (Dostal et al., 1986; Mansour and Pereira, 1987), but none have given a full account of how rotational moment arms vary with hip rotation and flexion. As a result, the rotational function of the muscles about the hip remains unclear. This makes it difficult to determine which muscles have the potential to contribute to excessive internal rotation and hampers the design of physical therapy and surgical procedures intended to reduce internal rotation.

The long-term goal of our work is to determine which muscles have the greatest potential to rotate the hip and to develop more effective methods to treat excessive internal rotation. In a preliminary study, we used a computer model of the lower limb (Delp et al., 1990) to

*Corresponding author. Tel.: 650-723-1230; fax: 650-725-1587; e-mail: sdelp@leland.stanford.edu

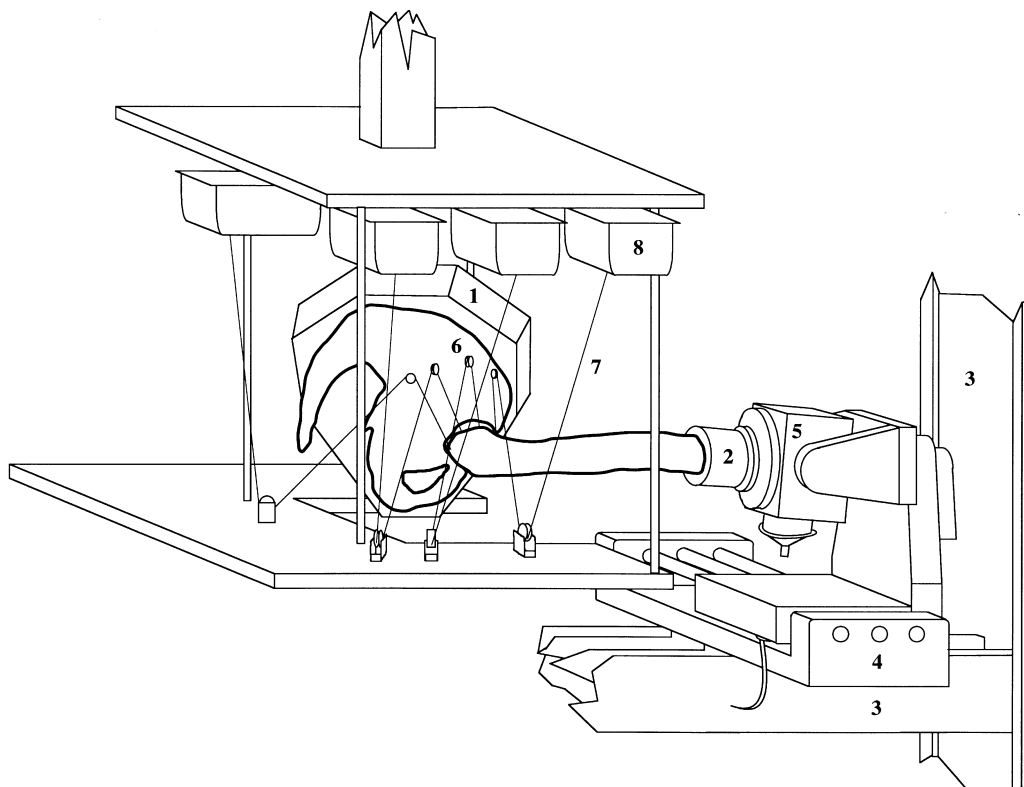

Fig. 1. Schematic view of the experimental setup used to measure muscle length as a function of hip rotation angle. The components of the system are: (1) site of pelvic fixation, (2) site of femoral fixation, (3) slides to adjust hip flexion angle, (4) slide to adjust hip abduction angle, (5) potentiometer to measure rotation angle, (6) pulleys at muscle attachments, (7) sutures, and (8) position transducers. The hip flexion angle is 90° in this illustration.

examine the rotational capacity of muscles about the hip. Analysis of this model suggested that maximum isometric rotation moments generated by muscles about the hip change with hip flexion; the moment-generating capacity increased for the internal rotators and decreased for the external rotators as the hip was flexed. Based on this analysis, we hypothesized that flexion of the hip would increase internal rotation moment arms and decrease external rotation moment arms of the major hip rotators. To test this hypothesis, we determined the rotational moment arms of selected hip muscles in four anatomical specimens at five hip flexion angles. These data provide the first detailed description of how rotational moment arms of many hip muscles are affected by hip flexion.

2. Methods

The rotational moment arms of gluteus maximus, gluteus medius, gluteus minimus, iliopsoas, piriformis, quadratus femoris, obturator internus, and obturator externus were estimated in four anatomical specimens. Moment arms were calculated from experimental measurements of the change in muscle length (An et al., 1984) with internal and external rotation of the hip.

Each of the four hemipelvic specimens was dissected. As each muscle was identified, isolated, and removed, its origin and insertion areas were marked with Toluidine blue dye. The location on the femur that corresponded to the attachment of the gluteus maximus to the iliotibial tract was also marked. All soft tissues were removed from the bones with the exception of the hip capsule and short (≈ 1 cm) tendinous insertions of the muscles. The hip capsule was left intact to hold the joint together during testing. The femur was cut transversely 25 cm below the greater trochanter. The entire hemipelvis and the portion of the sacrum and coccyx that provided the origin of the inferior compartment of the gluteus maximus were left intact.

The pelvis of each specimen was mounted in a custom designed testing apparatus (Fig. 1). The pelvis was secured to a metal container that was attached to the testing apparatus. Low melting point metal (Small Products, Inc., Miami Lakes, FL) was poured into the container to hold the pelvis in place. For initial positioning of the pelvis in this container, the bone was secured with 5–8 pins that were screwed into the ilium and the pubis. The pelvis was placed in a position corresponding to 0° flexion, 0° adduction, and 0° rotation with respect to the testing apparatus. This position was achieved when the line connecting the anterior superior iliac spine and

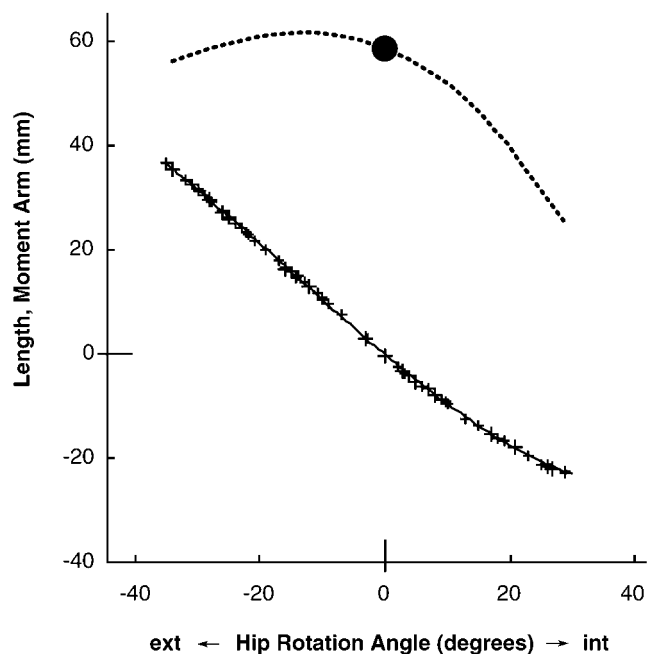

Fig. 2. Muscle length and moment arm vs. rotation angle for the most anterior pulley of the gluteus medius (GMED1) for one hip specimen at 90° hip flexion. The five test runs plotted here (+) demonstrate the consistency of the measurements. The solid curve is the fourth-order polynomial fit ($R^2 = 0.99$). The dotted curve is the calculated moment arm, which is the derivative of the polynomial multiplied by -1 . The large dot highlights the moment arm at 0° of hip rotation.

the most anterior point of the pubic symphysis was in the vertical plane of the testing apparatus and when the mid-sagittal plane at the pubic symphysis was vertical (Agur and Lee, 1991).

The femur was oriented with respect to the pelvis in neutral rotation and abduction. This neutral orientation was defined as the position at which the linea aspera of the femur was directly posterior and the shaft of the femur was adducted at an angle of 7° from the vertical in the coronal plane. When this orientation was achieved, the distal 5 cm of the femur was placed in a container which served as the mechanical interface between the femur and the testing apparatus. Molten metal was added to the container to fix the bone to the container, which was then mounted to the test apparatus. When mounted, the hip could be flexed from 0° (femur vertical) to 90° (femur horizontal).

Ethibond polyester suture (Ethicon, Somerville, NJ) was attached to the bone or tendon at the location of each muscle insertion on the femur. This suture was fed through a pulley attached to the pelvis at the corresponding muscle origin and secured to a position transducer (Celesco, Canoga Park, CA), which has an accuracy of ± 0.3 mm. Multiple sutures were used to represent the mechanical action of muscles with broad areas of attachment. Six pulleys were used to represent the broad origin of the gluteus maximus. Four pulleys were used for the



Fig. 3. Musculoskeletal model used to estimate muscle moment arms. Individual muscles and muscle compartments are represented by the lines. The dots represent the location of the muscle origins, insertions, and via points used to simulate the wrapping of muscles over deeper structures. The muscle compartments represented in this model correspond to the muscle compartments that were examined in the experiments (listed in Table 1).

gluteus medius, and three pulleys were used for the gluteus minimus. Single pulleys were placed approximately at the centroids of the origins of the piriformis, quadratus femoris, and obturator externus. Single pulleys were placed at the pseudo-origins of the iliopsoas and obturator internus. The pulley for the iliopsoas was placed at the midpoint of its width as it passed over the pelvic brim. The pulley for the obturator internus was placed at the midpoint of its width as it passed through the lesser sciatic foramen. In total, we measured the length changes of eighteen muscle compartments.

Muscle length changes were measured as a function of hip rotation angle at hip flexion angles of 0, 20, 45, 60, and 90°. At each hip flexion angle, the femur was slowly rotated 35° internally from its neutral position; the femur was then rotated back through the neutral position to 45° of external rotation, and finally back to its neutral position. This internal and external rotation movement together were considered as one run. Five runs were

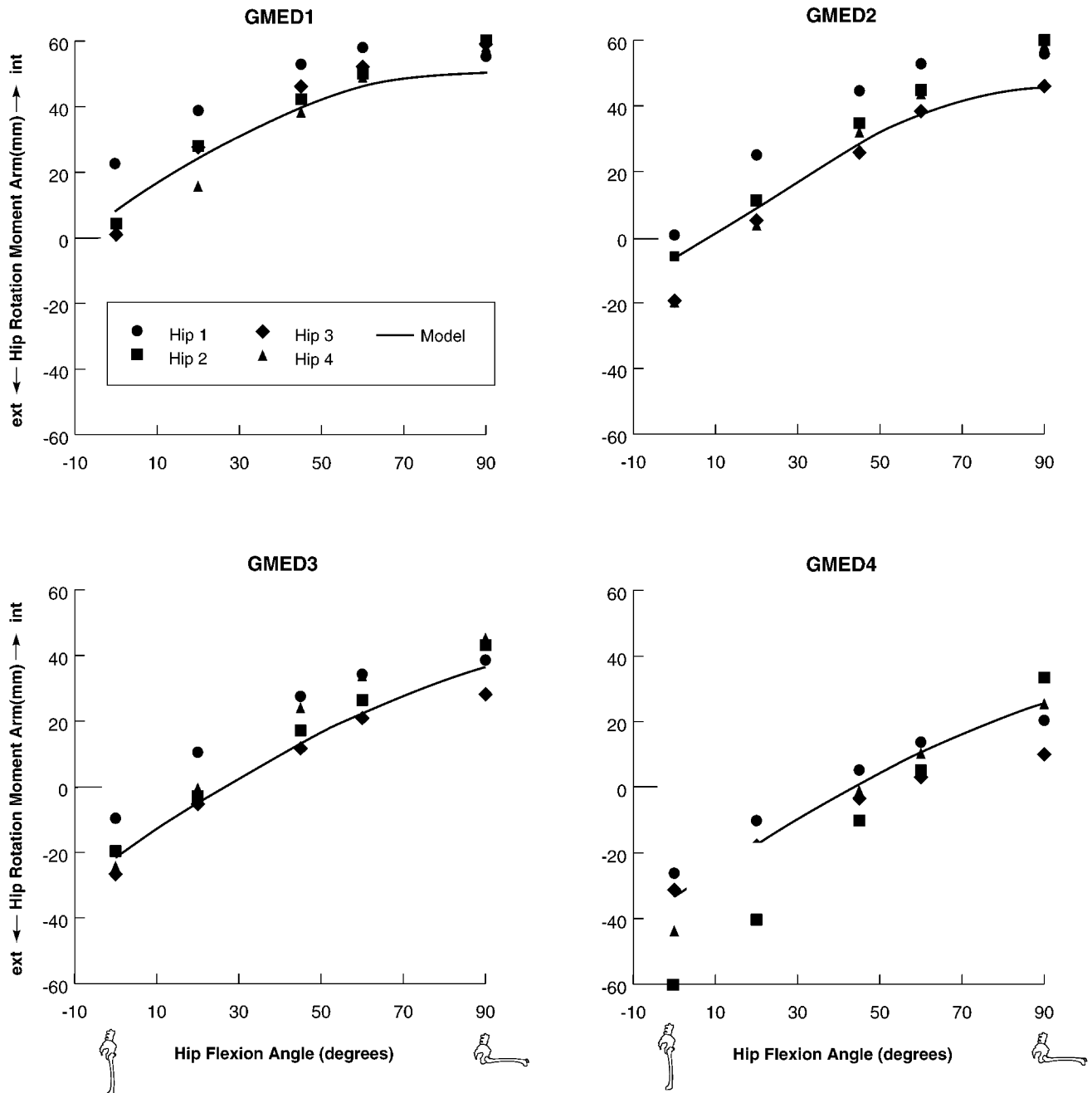

Fig. 4. Rotational moment arms of the gluteus medius vs. hip flexion. Internal rotation moment arms are positive and external rotation moment arms are negative. The rotational moment arms at 0° of hip rotation are plotted for 0, 20, 45, 60, and 90° hip flexion for the four specimens and the computer model. GMED1 is the anterior compartment of the gluteus medius and GMED4 is posterior compartment.

performed at each flexion angle. Flexion angle was measured using a goniometer. Length measurements from the position transducers and rotation angle from the potentiometer were sampled five times each second using an A/D board and a 486 computer. Each run took approximately 20 s. Lotus Measure software (Lotus Corporation, Cambridge, MA) controlled the data collection process.

Moment arms were calculated by computing the derivative of the muscle length vs. rotation angle curve (Fig. 2).

This was accomplished by fitting a fourth order polynomial to the length data using Matlab (MathWorks, Inc., Natick, MA). The polynomial was fit to data from the five test runs grouped together. Data were analyzed from the portion of each run during which the suture was lengthening because the displacement of the suture was smoother when it was lengthening. Correlation coefficients for the polynomial fits were computed with Matlab. The square of the correlation coefficient (R^2) was greater than 0.90 in almost every case. R^2 values lower

Table 1
Change in rotational moment arms (MA) with hip flexion

Muscle description	Abbreviation	MA at 0° flexion	MA at 90° flexion	Δ MA
Gluteus medius (Anterior compartment)	GMED 1	7 (10)	58 (2)	51 (12)
	GMED 2	-11 (10)	55 (6)	66 (10)
	GMED 3	-20 (8)	39 (8)	59 (9)
	GMED 4	-41 (16)	22 (10)	63 (25)
Gluteus minimus (Anterior compartment)	GMIN 1	18 (16)	35 (14)	17 (20)
	GMIN 2	-10 (5)	42 (6)	52 (10)
(Posterior compartment)	GMIN 3	-30 (6)	26 (18)	56 (21)
	GMIN 4	-18 (10)	12 (7)	6 (3)
Gluteus maximus (Anterior compartment)	GMAX 1	-20 (13)	46 (8)	66 (7)
	GMAX 2	-26 (18)	33 (6)	59 (18)
	GMAX 3	-28 (12)	13 (6)	41 (7)
	GMAX 4	-29 (14)	1 (3)	30 (14)
	GMAX 5	-15 (3)	-3 (3)	12 (3)
	GMAX 6	-18 (10)	-12 (7)	6 (3)
(Posterior compartment)	GMAX 6	-18 (10)	-12 (7)	6 (3)
Piriformis		-29 (7)	14 (7)	43 (5)
Iliopsoas		2 (2)	-4 (5)	-6 (4)
Quadratus femoris		-22 (7)	-27 (11)	-5 (16)
Obturator internus		-30 (3)	-7 (4)	23 (3)
Obturator externus		-14 (2)	-26 (4)	-12 (4)

1. The average for the four specimens and one standard deviation (in parentheses) is reported in mm.
2. Rotational moment arms were measured over a range of hip rotation, but only the moment arm at 0° hip rotation is reported here.
3. Positive moment arm indicates internal rotation; negative moment arm indicates external rotation.
4. A positive number in the Δ MA column indicates an increasing internal rotation moment arm, a decreasing external rotation moment arm, or a switch from external rotation to internal rotation moment arm.

than 0.90 occurred only for muscles that had length changes that were less than 2 mm. Moment arms calculated from these small length changes were near zero regardless of the fitting technique that was used. Fifth-order polynomials showed negligible difference in the goodness of fit and, therefore, were not used. Derivatives of the polynomial were multiplied by -1 so that internal rotation moment arms were positive and external rotation moment arms were negative.

We modified the computer model developed by Delp et al. (1990) to reflect the increased number of muscle compartments of the gluteus maximus and gluteus medius (Fig. 3). The number of compartments used to represent gluteus maximus was increased from three to six, and the number of compartments used to represent gluteus medius was increased from three to four. The origin to insertion path of the psoas was altered slightly to better represent its rotational function. The rotational moment arms computed with the model were compared to the moment arms that were calculated from the experimental data.

3. Results

The rotational moment arms of the four compartments of gluteus medius change substantially with hip flexion (Fig. 4). In 0° flexion, the anterior compartment of the

gluteus medius (GMED1) has a small internal rotation moment arm, while the other compartments (GMED2, GMED3, and GMED4) have external rotation moment arms. As the hip is flexed, the internal rotation moment arm of the anterior compartment increases, and the moment arms of the other compartments switch from external rotation to internal rotation.

This trend toward increasing internal rotation moment arm with hip flexion is apparent in 15 of the 18 muscle compartments we examined (Table 1). For example, the posterior compartment of the gluteus minimus (GMIN3) has an average external rotation moment arm of 30 mm with the hip at 0° flexion, but has an internal rotation moment arm of 26 mm at 90° flexion. Similarly, the piriformis has an average external rotation moment arm of 29 mm with 0° flexion; with 90° flexion, however, it has an internal rotation moment arm of 14 mm. The only muscles we studied that do not have this trend toward internal rotation are the obturator externus, quadratus femoris, and iliopsoas.

The gluteus maximus has a large capacity for external rotation when the hip is at 0° flexion. At 0° flexion all of the compartments of gluteus maximus have an external rotation moment arm (Fig. 5). However, as the hip is flexed, the anterior compartments of the gluteus maximus (GMAX1 and GMAX2) switch from external rotation to internal rotation moment arms. The posterior compartments of the gluteus maximus (GMAX5 and

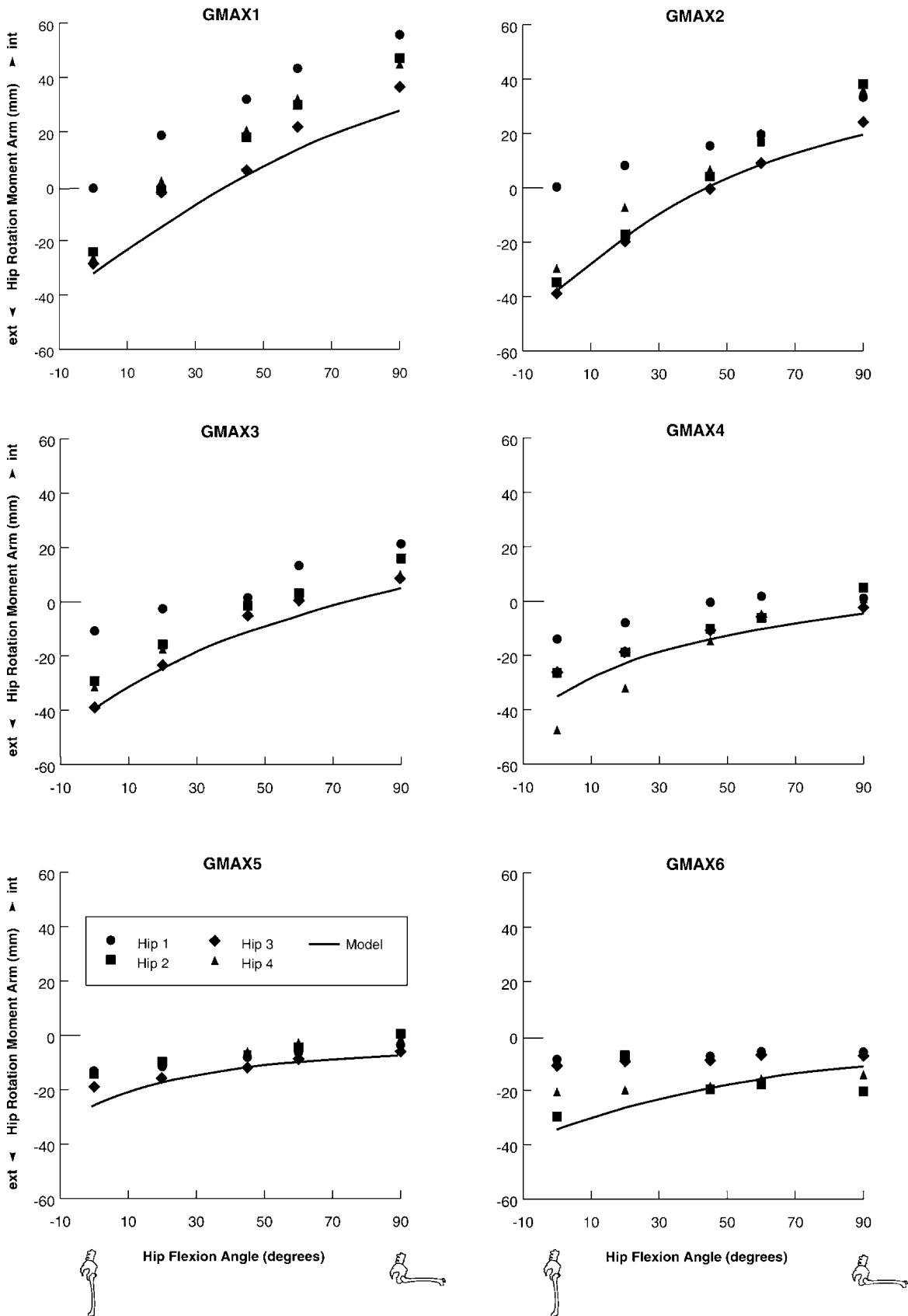

Fig. 5. Rotational moment arms of the gluteus maximus vs. hip flexion. Internal rotation moment arms are positive and external rotation moment arms are negative. The rotational moment arms at 0° of hip rotation are plotted at 0, 20, 45, 60, and 90° hip flexion for the four specimens and the computer model. GMAX1 is the anterior (and superior) segment, and GMAX6 is the posterior (and inferior) segment.

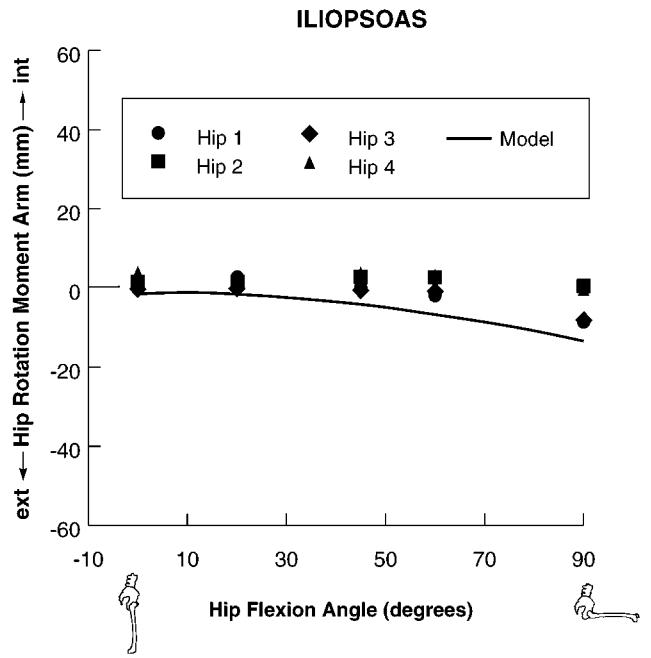
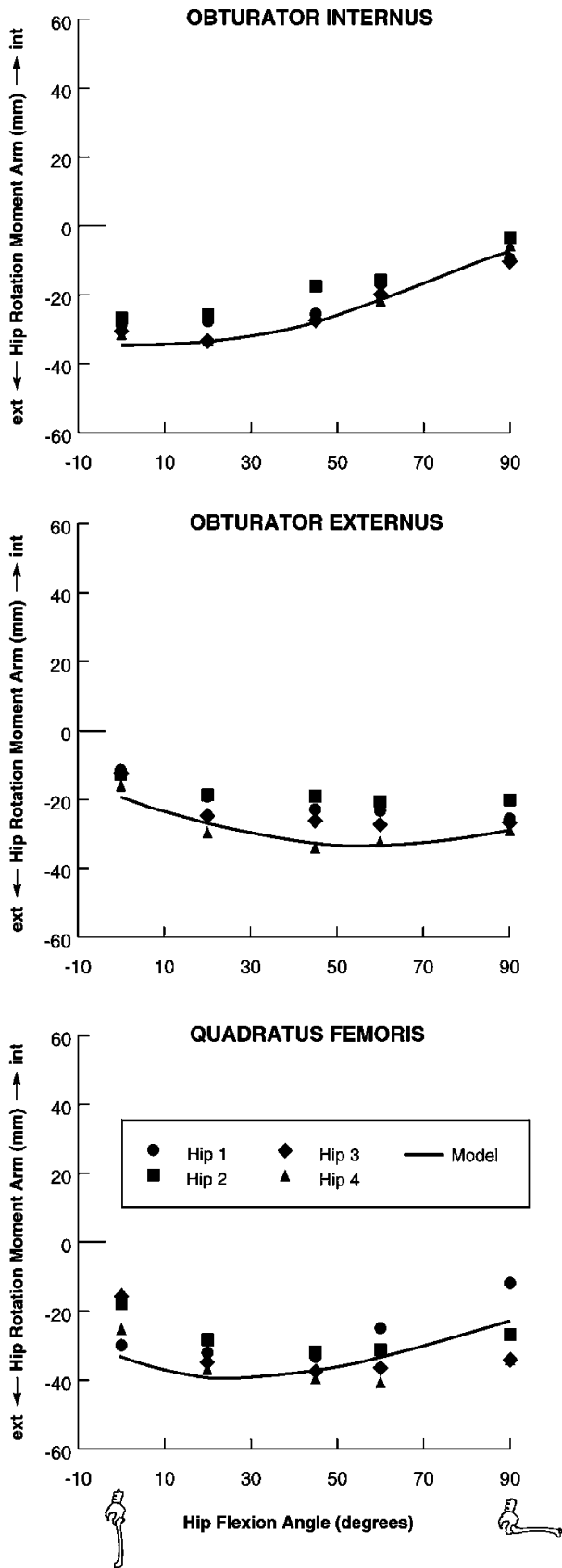

Fig. 7. Rotational moment arm of the iliopsoas vs. hip flexion. The rotational moment arms at 0° of hip rotation are plotted at 0, 20, 45, 60, and 90° hip flexion for the four specimens and the computer model. This muscle has a small rotational moment arm throughout the range of flexion angles tested.

GMAX6) remain external rotators throughout the range of hip flexion but have a reduced external rotation moment arm in flexion, on average. In general, the external rotation moment arms of gluteus maximus calculated with the model are larger (i.e., more negative in Fig. 5) than the average of the experimentally determined moment arms. This occurs because the computer model includes via points between the muscle origin and insertion to represent wrapping of the muscle over deeper structures, whereas the sutures used to represent the muscles in the experiment coursed directly from origin to insertion.

The muscles that are considered to be dedicated external rotators: obturator internus, obturator externus, and quadratus femoris, have external rotation moment arms throughout the range of flexion angles (Fig. 6). The iliopsoas has a small rotational moment arm throughout the range of flexion (Fig. 7); at 90° flexion this muscle has a slight external rotation moment arm.

Fig. 6. Rotational moment arms of the quadratus femoris, obturator externus, and obturator internus. Internal rotation moment arms are positive and external rotation moment arms are negative. The rotational moment arms at 0° of hip rotation are plotted at 0, 20, 45, 60, and 90° hip flexion for the four specimens and the computer model. Each of these muscles has an external rotation moment arm for all flexion angles.

4. Discussion

The purpose of this study was to clarify the effect of hip flexion on the rotational moment arms of muscles about the hip. We hypothesized that internal rotation moment arms would increase and external rotation moment arms would decrease with hip flexion. Experimental results and computer simulations revealed that this trend toward increasing internal rotation moment arm with hip flexion was apparent in 15 of the 18 muscle compartments we examined. Before discussing the implications of these results, some of the limitations of this study are considered below.

We have not measured the rotational moment arms of all of the muscles that cross the hip. The muscles examined in this study were chosen because they are generally considered to be important rotators of the hip. However, other muscles, including the hamstrings and adductors, are frequently lengthened surgically in an attempt to correct excessive internal rotation of the hip. Future studies should be performed to measure the rotational moment arms of the hamstrings and adductors, and to determine how the rotational capacity of these muscles is altered with hip flexion.

The anatomical specimens and the computer model used in this study represent normal adult musculoskeletal geometry. However, many individuals with rotational abnormalities are children who may have skeletal deformities, such as excessive femoral anteversion. This study did not examine how subject size or skeletal deformities may affect the rotational moment arms of the muscles. Certainly, future work is needed to determine how muscle moment arms vary among subjects of different sizes and to understand how bone deformities affect the rotational moment arms of the hip muscles.

In the computer model and the experiments we attempted to represent musculoskeletal geometry accurately by using multiple compartments to represent muscles with broad attachments. In the computer model, we also included via points between muscle origins and insertions to represent the wrapping of the muscles over deeper structures. However, in the experiments, deep muscles were removed, and sutures were used to represent the lines of action of muscles. This may have introduced errors into the measured moment arms, especially for the gluteus maximus, which wraps over deeper muscles and inserts laterally on the iliotibial tract. The gluteus maximus may have larger external rotation moment arms than illustrated by the experimental results because of the limitations of the experimental setup.

The use of polynomials to fit experimental data can introduce errors into calculated moment arms. The polynomial fit was chosen in this study because it effectively smoothed noise evident in the numerical derivatives of the muscle length data, whereas other fitting methods, such as cubic and quintic splines, did not. Several

polynomials had a relatively low correlation ($R^2 < 0.90$) with the experimental data. This occurred only when the muscle excursions were very small (< 2 mm over the entire range of motion); in these cases, it is clear that the moment arm is near zero regardless of the method used to represent the data.

Our results sometimes showed large variations in the magnitude of the moment arms between the specimens. Analysis of the computer model revealed that the magnitudes of the rotational moment arms are sensitive to the position of the muscle origin (i.e., the position of the pulleys on the bones in the experiment). For example, anterior displacement of the origin of the gluteus medius, which may result from a broader iliac crest, produced a larger internal rotation moment arm. Further investigation is needed to determine whether skeletal geometry is responsible for the differences in the moment arms between the specimens. Despite the variability in the magnitudes of the rotational moment arms, the same trends were evident in almost every specimen and in the model.

Our results are consistent with the few quantitative descriptions of rotational moment arms that have been published previously. Dostal et al. (1986) reported that the internal rotation moment arm of the anterior compartment of gluteus medius increased by 49 mm as the hip was flexed 90° ; this is similar to the 51 mm increase of GMED1 shown in Table 1. Mansour and Pereira (1987) reported that the intermediate compartment of the gluteus medius switched from external rotation to internal rotation at approximately 20° flexion, which is consistent with our results (see GMED2 and GMED3 in Fig. 4). Mansour and Perira (1987) also reported a decrease in the external rotation moment arm of the gluteus maximus with hip flexion, as we have demonstrated here.

Previous studies have suggested that the iliopsoas plays an important role in producing hip rotation (Samilson, 1981). Our results, however, show very small rotational moment arms for the iliopsoas and support the notion that this muscle plays a minor role in producing rotational moments about the hip (Bleck, 1987). A short or spastic iliopsoas may contribute to excessive internal rotation indirectly; if it causes excessive hip flexion, it may shift the balance of the hip rotators toward internal rotation.

This study may have important implications for the treatment of persons who walk with excessive flexion and internal rotation of the hip. Our results demonstrate that internal rotation moment arms increase and external rotation moment arms decrease for many muscles as the hip is flexed. This suggests that excessive internal rotation may result from excessive flexion. The data also suggest that the excessive internal rotation of the hip may decrease if the exaggerated hip flexion is corrected. If physical therapy or surgery is effective in reduction of hip flexion, internal rotation of the hip may also improve.

We found that the gluteus maximus has a large capacity for external rotation when the hip is extended. Enhancing activation of the gluteus maximus, a muscle that is often underactive in persons with cerebral palsy, may help correct excessive hip flexion and internal rotation of the hip. These characteristics of rotational moment arms should be considered when developing treatments of movement abnormalities that include excessive flexion and internal rotation of the hip.

Acknowledgements

This work was supported by NIH (R01-HD33929), the United Cerebral Palsy Foundation, and the Hearst Foundation.

References

- Agur, A.M.R., Lee, M.J., 1991. *Grant's Atlas of Anatomy*. Williams and Wilkins, Baltimore.
- An, K.N., Takahashi, K., Harrigan, T.P., Chao, E.Y., 1984. Determination of muscle orientations and moment arms. *Journal of Biomechanical Engineering* 106, 280–282.
- Bleck, E.E., 1987. *Orthopaedic Management in Cerebral Palsy*. Mac Keith Press, London.
- Delp, S.L., Loan, P., Hoy, M.G., Zajac, F.E., Topp, E.L., Rosen, J.M., 1990. An interactive graphics-based model of the lower extremity to study orthopaedic surgical procedures. *IEEE Transactions Biomedical Engineering* 37, 757–767.
- Dostal, W.F., Soderberg, G.L., Andrews, J.G., 1986. Actions of hip muscles. *Phys Therapy* 66, 351–361.
- Hoy, M.G., Zajac, F.E., Gordon, M.E., 1990. A musculoskeletal model of the human lower extremity: the effect of muscle, tendon, and moment arm on the moment-angle relationship of musculotendon actuators at the hip, knee, and ankle. *Journal of Biomechanics* 23, 157–169.
- Mansour, J.M., Pereira, J.M., 1987. Quantitative functional anatomy of the lower limb with application to human gait. *Journal of Biomechanics* 20, 51–58.
- Murray, W.A., Delp, S.L., Buchanan, T.S., 1995. Variation of muscle moment arms with elbow and forearm position. *Journal of Biomechanics* 28, 513–525.
- Samilson, R.L., 1981. Current concepts of surgical management of deformities of the lower extremities in cerebral palsy. *Clinical Orthopaedics and Related Research* 158, 99–107.
- Skaggs, D.L., Kaminsky, C.K., Eskander-Richards, E., Reynolds, R.A.K., Tolo, V.R., Bassett, G.S., 1997. Psoas over the brim lengthenings: anatomic investigation and surgical technique. *Clinical Orthopaedics and Related Research* 339, 174–179.
- Sutherland, D.H., Zilberfarb, J.L., Kaufman, K.R., Wyatt, M.P., Chambers, H.G., 1997. Psoas release at the pelvic brim in ambulatory patients with cerebral palsy: operative technique and functional outcome. *Journal of Pediatric Orthopaedics* 17, 563–570.